

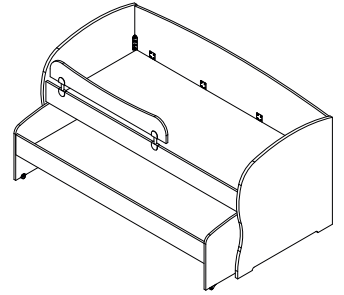

VAŽNO – PRE UPOTREBE PAŽLJIVO PROČITAJTE I SAČUVAJTE UPUTSTVO
IMPORTANT – READ CAREFULLY – RETAIN FOR FUTURE REFERENCE
WICHTIG – SORGFÄLTIG LESEN UND AUFBEWAHREN
ВАЖНО – ПРОЧИТИТЕ ВНИМАТЕЛЬНО – СОХРАНИТЬ ДЛЯ ДАЛЬНЕЙШЕГО ИСПОЛЬЗОВАНИЯ

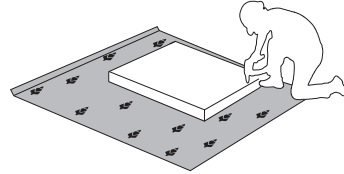
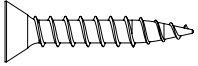

KRD1

LWH - 2050x980x1022
6451 7.11.2018.

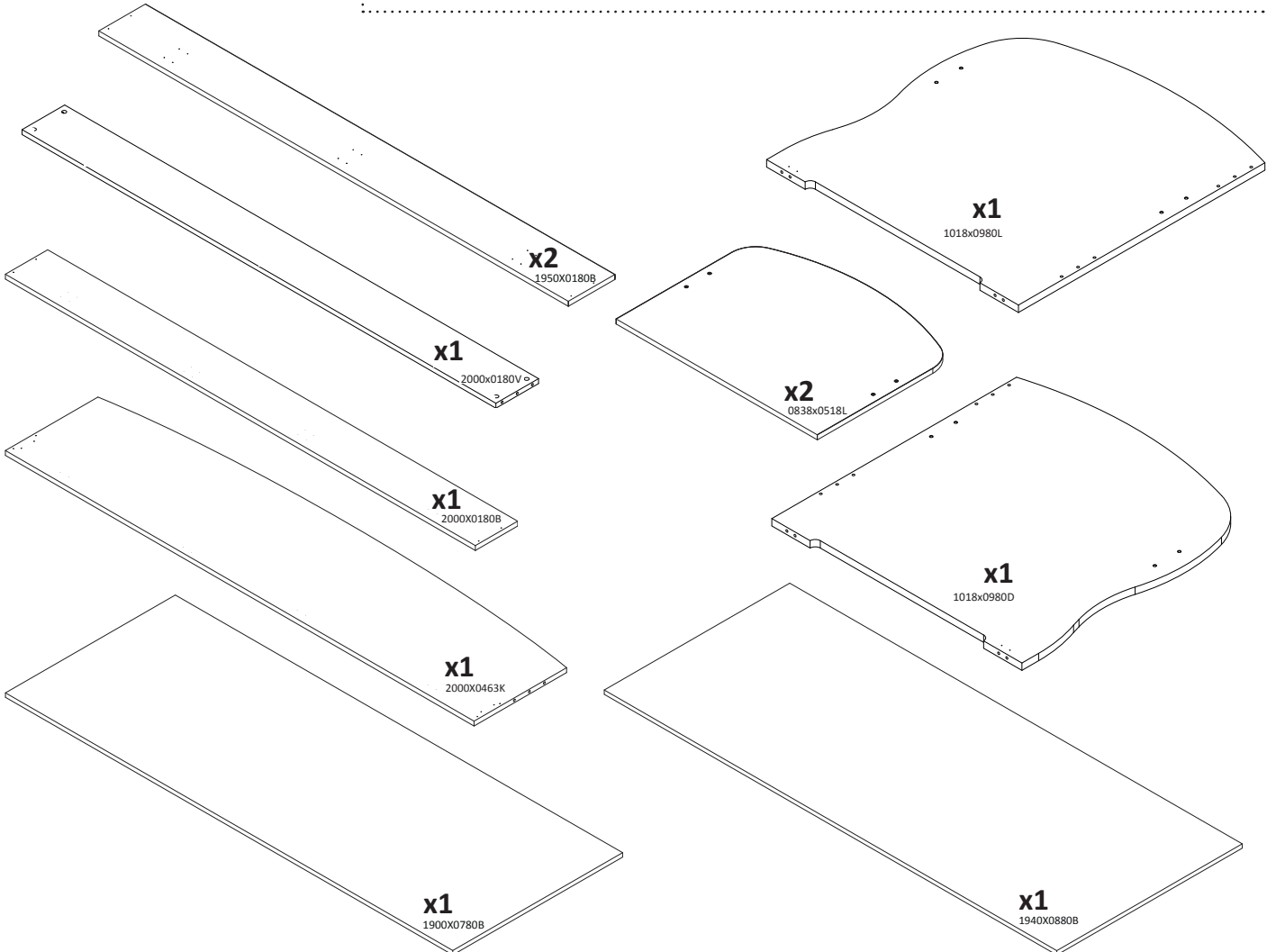
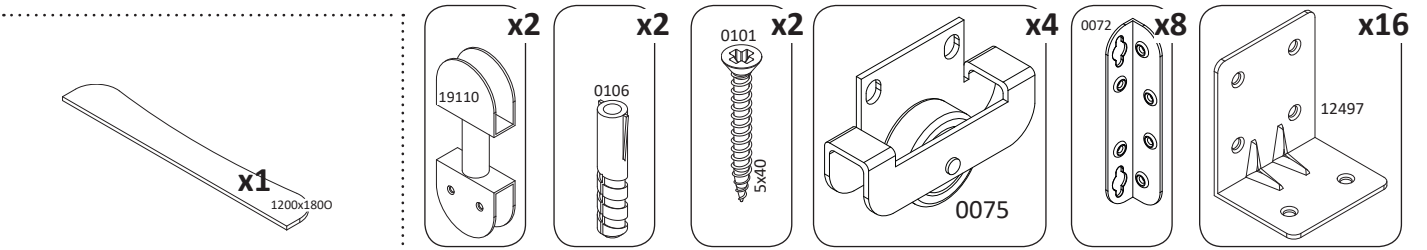
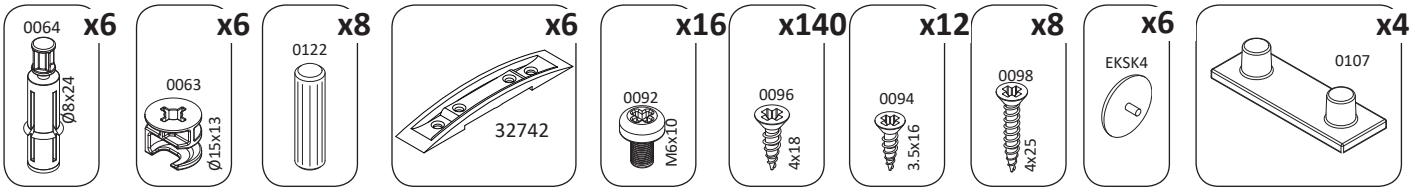

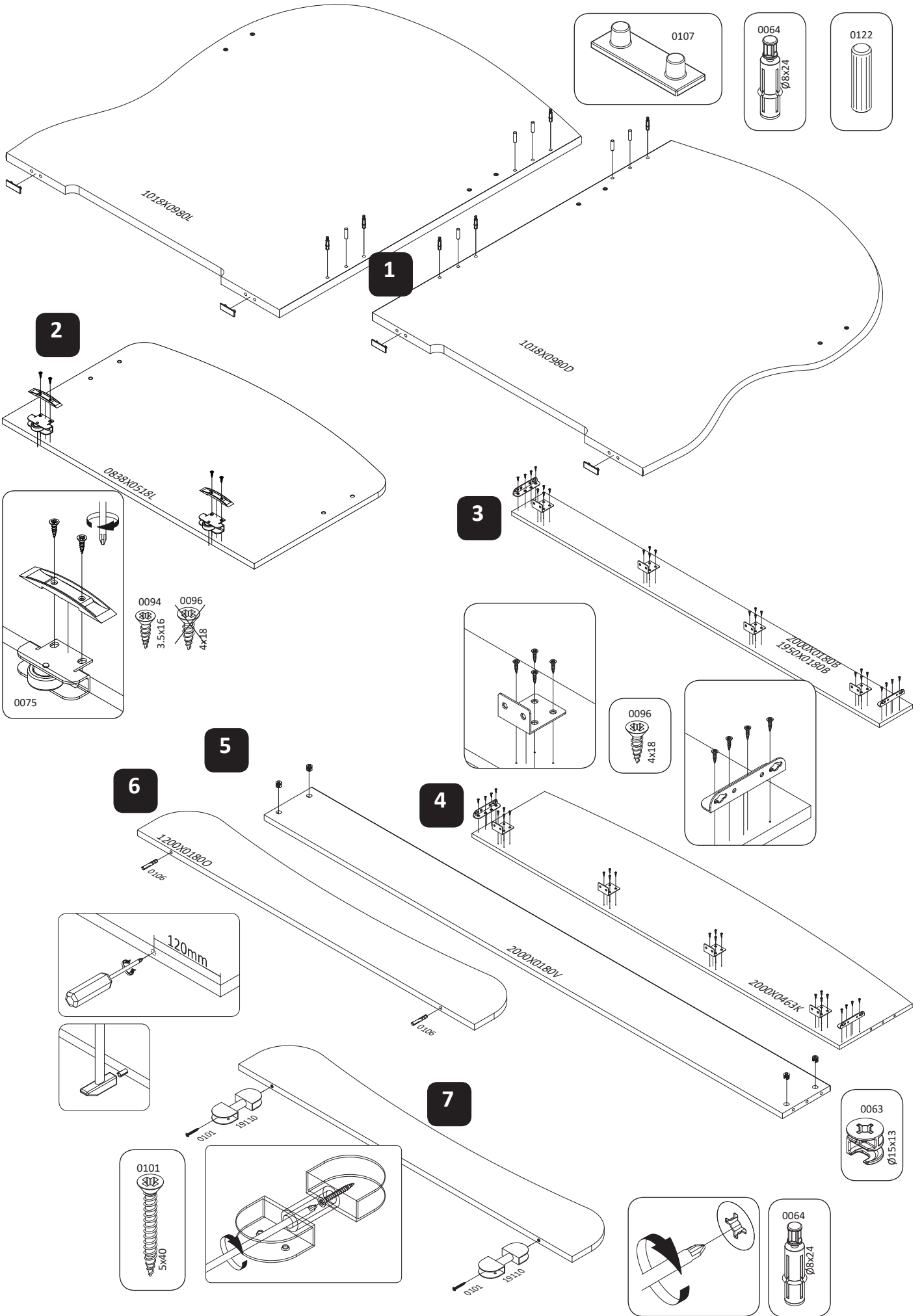

8

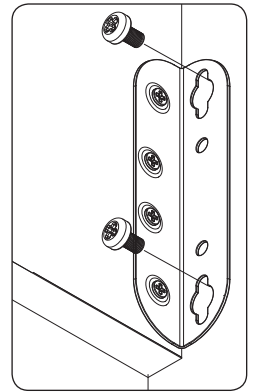
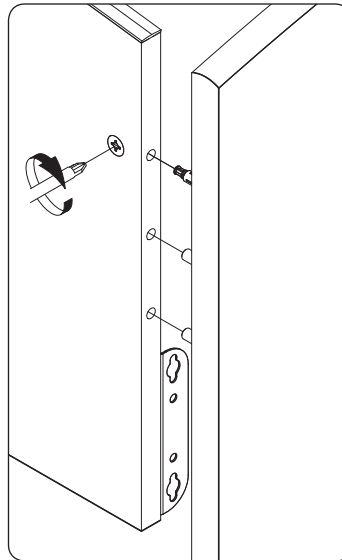
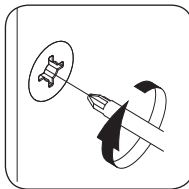
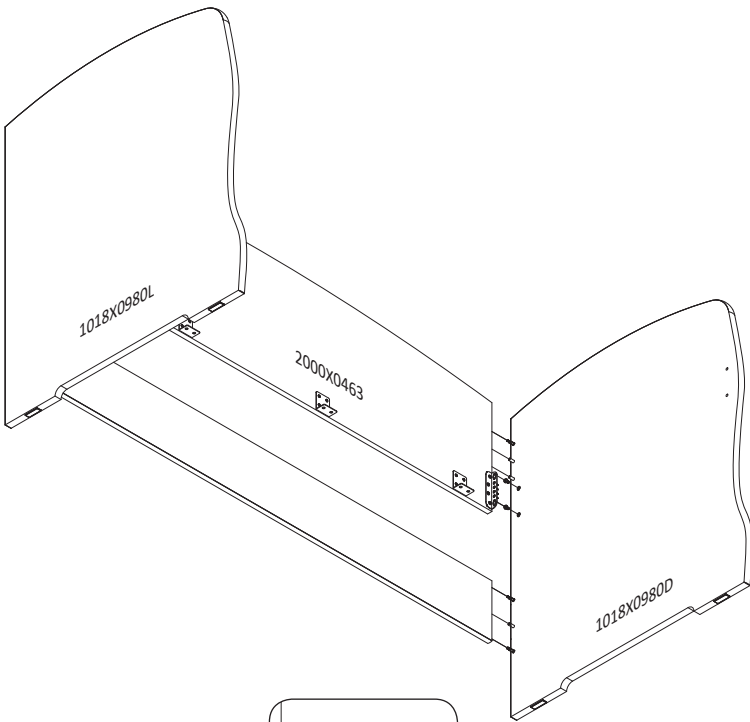

9

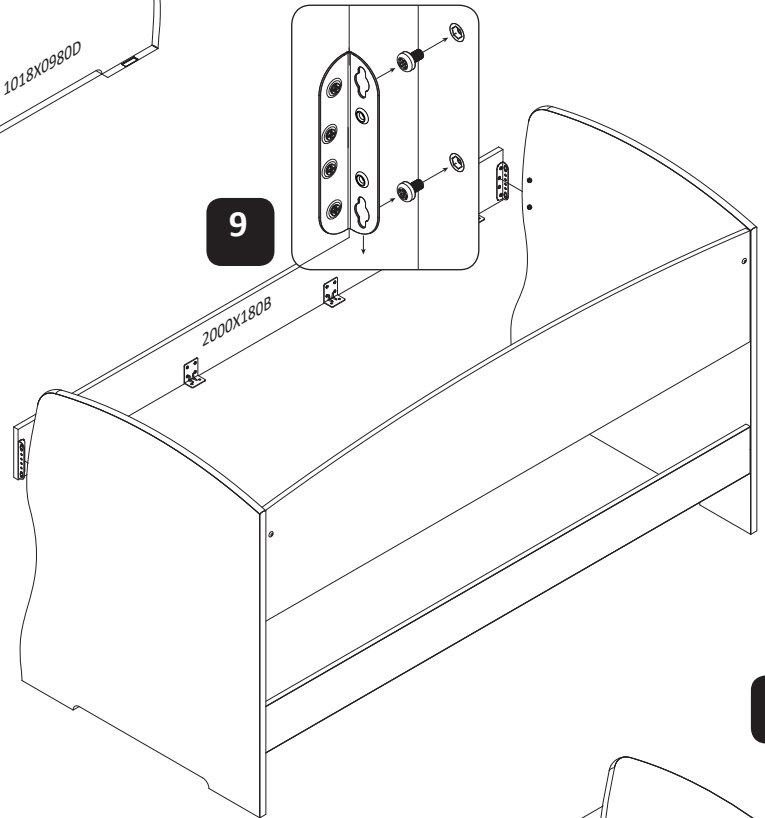

10

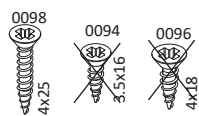
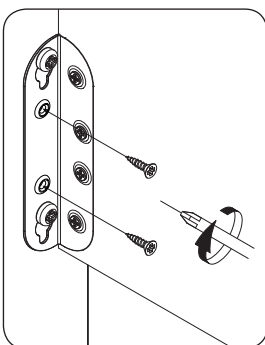
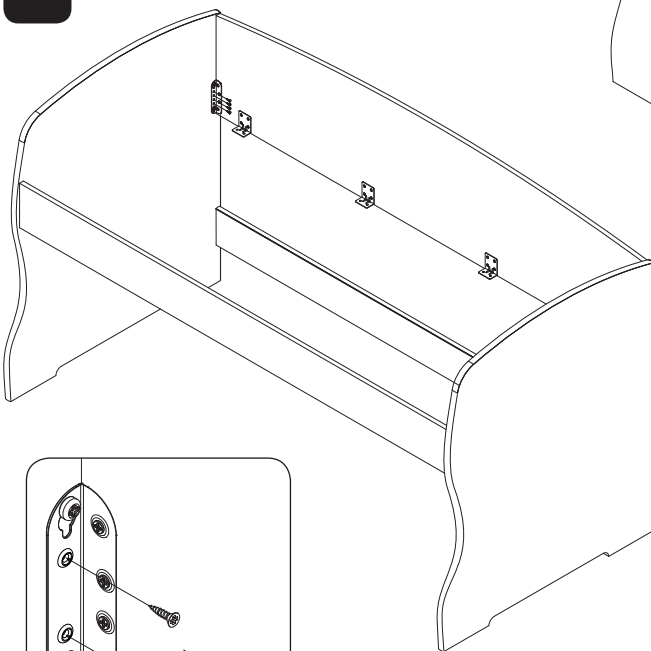

11

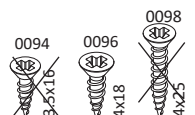
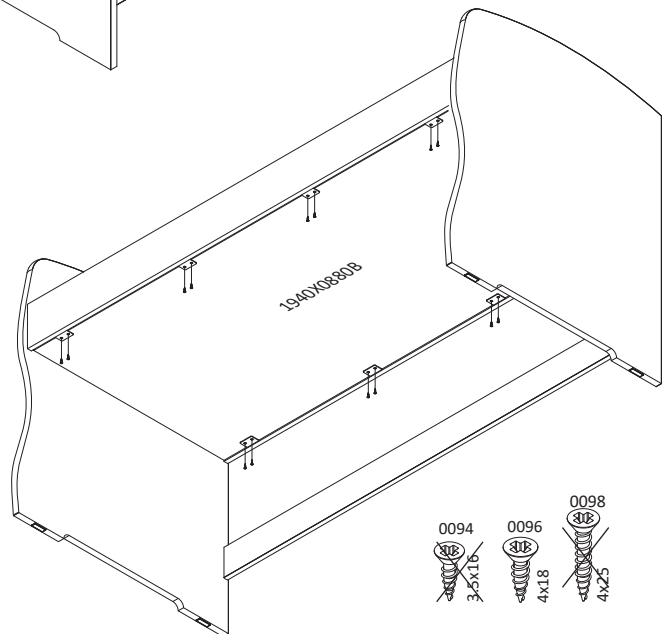

12

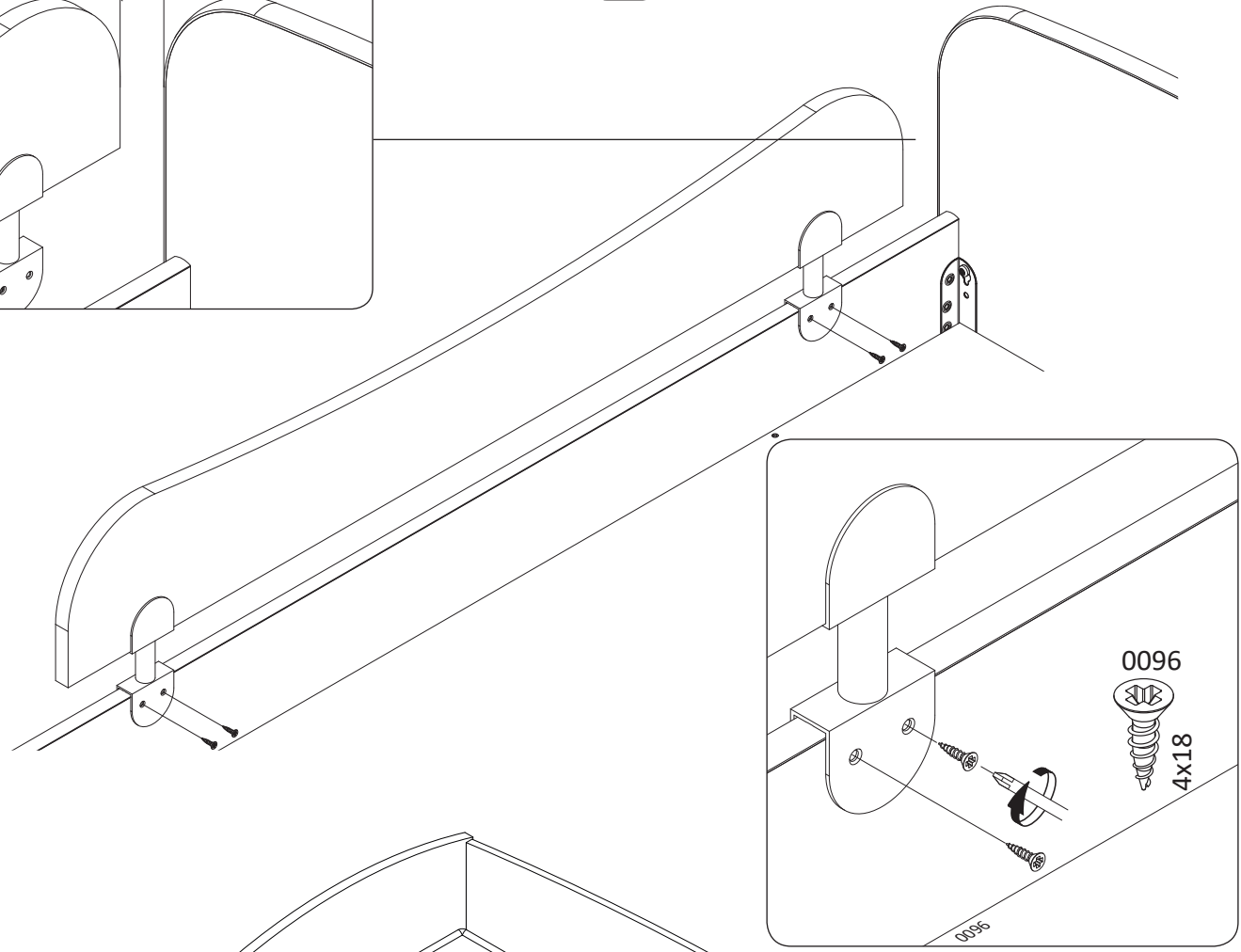
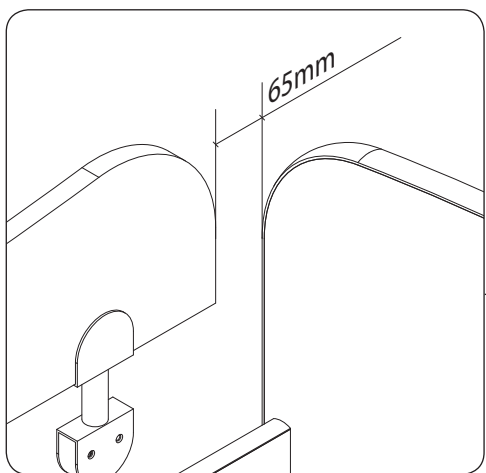

13

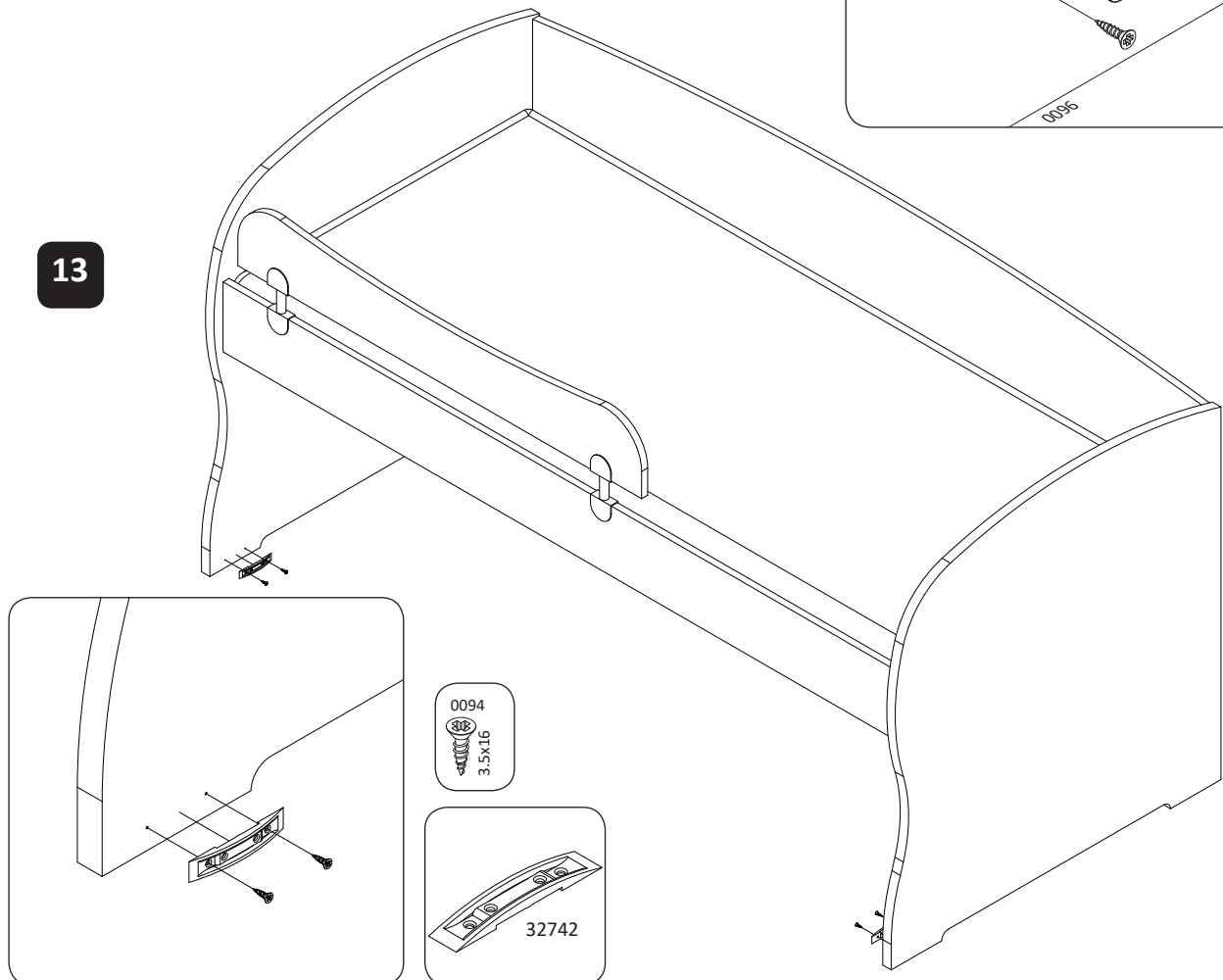

0094
3.5x16

32742

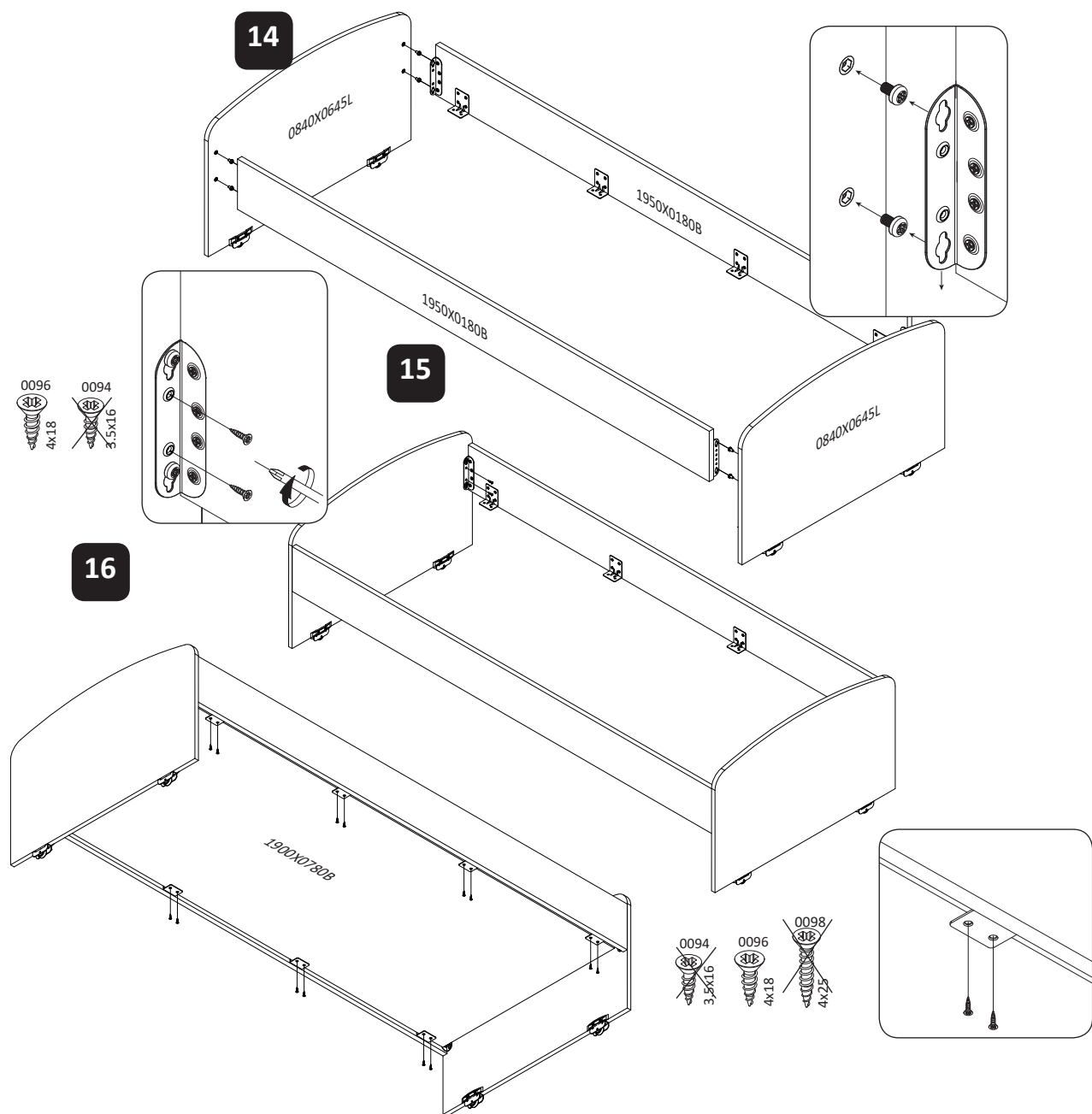

PAŽNJA !!!

Montaža ovog kreveta zahteva dve osobe.

- Ovaj krevet je predviđen za dušek dimenzija: 900x2000x150mm i 800x1950x150mm.
- **Minimalna** debljina duška ne sme da bude manja od 150mm
- **Maksimalna** debljina duška ne sme biti veća od 220mm
- **Strogo preporučujemo korišćenje ogradice OK120 i maksimalnu visinu duška 150mm radi bezbednosti vaše dece.**

- Svi zavrtnji i vijci treba da budu dobro zategnuti i treba voditi računa da nema labavih spojeva.
- Obavezno proveravati zavrtnje i vijke sa vremena na vreme, i po potrebi ih zatezati.
- Ni pod kojim uslovima krevet ne koristite ako su njegovi delovi oštećeni ili nedostaju.

UPOZORENJE !!!

- Deca mogu da se zaglave između kreveta i zida. Da bi izbegli rizike od povreda, razmak između kreveta i zida **ne sme da bude veći od 75 mm ili mora biti veći od 230 mm**
- Visoki i kreveti na sprat nisu predviđeni za decu **mlađu od šest godina** zbog rizika od povreda prilikom pada.
- Molimo da vodite računa da sa gornjeg kreveta ne vise predmeti kao što su kanapi, konopci, trake, kablovi, jer se dete može njima ugušiti.
- Zabranjen je boravak više od jedne osobe na gornjem krevetu.
- Zabranjeno je igrati se na krevetu i ispod kreveta, kao i skakati po krevetu.

- Ovaj krevet je namenjen za maksimalno opterećenje od 100 kg na svakoj spavaćoj površini.
- Zaštitne ograde na gornjem krevetu moraju uvek biti ispravno postavljene

VAŽNO:

- Sačuvajte ovo uputstvo za buduće potrebe.
- Objasnite deci kako treba da koriste krevet.

ATTENTION !!!

This bunk bed should be assembled by 2 persons.

- This bed is designed to use a mattress in size: 900x2000x150mm and 800x1950x150mm.
- **Minimum** thickness of mattress must not be under 150mm
- **Maximum** thickness of mattress must not be over 150mm
- **We strongly recommend the use of railing OK120 and a maximum height of mattress 150mm for the safety of your children.**

- All assembly fastenings should always be tightened properly and care should be taken that no fittings are loose;
- Please check the screw joints from time to time and - if necessary - tighten them again.
- Under no circumstances should you use the bed if any of the parts are missing or broken.

WARNING !!!

- Children can become trapped between the bed and the wall. To avoid risk of serious injury the distance between the top safety barrier and the wall **shall not exceed 75 mm or shall be more than 230 mm**
- High beds and the upper bed of bunk beds are not suitable for children **under six years** due to the risk of injury from falls
- Please ensure that there are no ropes, strings, cords, belts, harnesses or bands attached to, or hanging from the bunk bed, as these could strangle your child.
- Prohibit more than one person in upper bunk
- Do not allow horseplay on or under the bed and prohibit jumping on the bed

- This bed is designed for a maximum load of 100 kg on each sleeping surface
- Safety railings must always be in proper place in upper bunk

IMPORTANT:

- Keep this instruction for the future
- Explain to the children rules above for using the bed